

Client _____ Quantity _____
 Project _____ Position _____

Pastry EN60x40 counter 2 doors

Model: TA13/1MJ-710

Cod: T20202000201



Technical data

Top:	With top and splashback
Gross capacity:	389 lt
Temperature range:	-2°+8°C
Refrigerant unit:	Plug-In
Energetic class:	B
Energy efficiency index:	30,1
Annual consumption:	734 kW/h annum
24h consumption:	2,011 kW/h/24h
Climate class:	5
Cooling gas:	R290
Defrost:	Hot gas
Body height:	710 mm
Valve:	Supplied standard with solenoid
Dimensions:	1450×800×950 mm
Packing dimensions:	1545×900×990 mm
Gross weight:	150 Kg
Voltage:	220-240 V - 50 Hz
Total rate:	250 W
Absorbed Current:	1,15 A
Cooling capacity:	406 W*
*:	Evap. -10°C Cond. +55°C

Features

Standard equipment:	8 slides EN60x40
Control:	Electronic, display flush with the panel
Doors:	2 doors, self-closing, reversible with 105° stop
Door gasket:	Magnetic, triple chamber and easily replaceable
Insulation:	60 mm thickness - CFC/HCFC free
Exterior/interior finishing:	Exterior interior and back in AISI 304 stainless steel. Base in colaminated steel
Inner corners:	Rounded for easy cleaning and ensuring maximum hygiene
Handle:	Stainless steel AISI 304, 2 mm thick
Racks and slides:	Stainless steel AISI 304
Feets:	Stainless steel AISI 304, adjustable h 100-150 mm
Cosmo:	Ready for connection to Cosmo Hub

Accessories and variants

Drawers 1/2	4 Swivel and brake castors h 128 mm
Drawers 1/3	Aluminium coated backing-pan EN60x40 h 20 mm
Drawers 1/3 + 2/3	Stainless steel shelf EN60x40
Technical compartment on the left	Plastic coated shelf EN60x40
Lock with key for drawer 1/2	Pair of type L slides 605 mm
Lock with key for drawer 1/3	IP44 schuko socket with cover
Lock with key for drawer 1/3 + 2/3	Serial interface, RS485 cable
RAL customisable colouring	Cosmo connection kit
Plug-in water unit	Removable plinth EN 2D h 50 mm
Stainless steel evaporator	Removable plinth EN 2D h 100 mm
Power supply frequency 60Hz	Removable plinth EN 2D h 150 mm
Other special voltage	
Internal hygiene H3	
Granite flat worktop	
Granite worktop with splashback	
Service water sink Ø 300 mm	
Single lever mixer hole Ø 3/4	
Adjustable feet h 145/195 mm	

COSMO - wi-fi control

Cosmo is the wi-fi technology that allow to connect and monitor all Coldline appliances. Connect Pastry counters to a Cosmo hub (MODI, VISION or LEVTRONIC) and from the app you can check the operating conditions of each machine and receive alerts in case of abnormal functioning.

*The installation requires a kit for the replacement of the racks

Technical draw

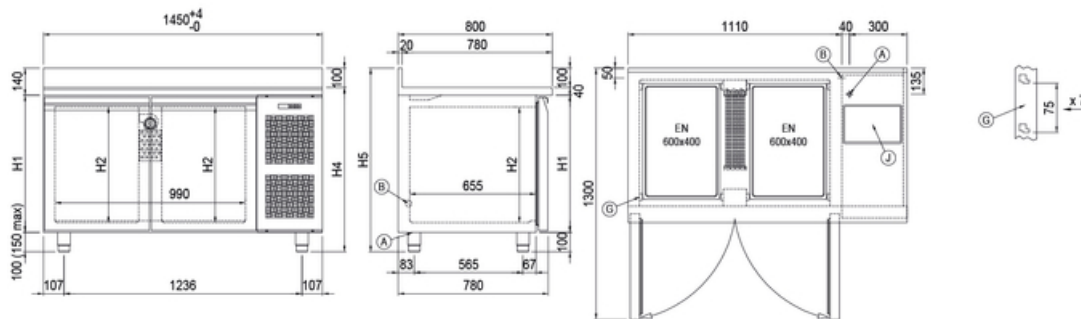

H1	H2	H4	H5
710	600	850	950

- A:** Power supply cable outlet **B:** Condensation water drain **G:** Racks pitch
- J:** Automatic evaporation of condensing water