



Client _____ Quantity _____
 Project _____ Position _____

Vision F30 cabinet

Model: AF30/1M

Cod: A64300800101

Technical data

| | |
|----------------------------|---------------------------------|
| Max capacity: | 33 trays EN60x40 h 20 mm |
| Gross capacity: | 622 lt |
| Temperature range: | -6°+40°C |
| Ventilation range: | 25% - 100% |
| Humidity range: | 45% - 95% with humidifier |
| Humidifier: | Incluso |
| Refrigerant unit: | Plug-In |
| Climate class: | 5 |
| Cooling gas: | R452A |
| Defrost: | Electric |
| Valve: | Supplied standard with solenoid |
| Dimensions: | 810×796×2215 mm |
| Packing dimensions: | 830×830×2250 mm |
| Gross weight: | 190 Kg |
| Voltage: | 220-240 V - 50 Hz |
| Total rate: | 1020 W |
| Absorbed Current: | 4,7 A |
| Cooling capacity: | 668 W* |
| *: | Evap. -10°C Cond. +55°C |

Features

| | |
|-------------------------------------|---|
| Functions: | Retarder prover, manual proving, continuous cycle, storage, chocolate, thawing, ice cream |
| Standard equipment: | 20 slides for EN60x40 trays, LED lighting |
| Control: | 7" touch screen display with USB port |
| Doors: | 1 door, self-closing with a 105° stop, right hinged |
| Door gasket: | Magnetic, triple chamber and easily replaceable |
| Insulation: | 75 mm thickness - CFC/HCFC free |
| Exterior/interior finishing: | Exterior and interior AISI 304 stainless steel. Back, base and internal technical compartment in galvanized/ colaminated steel. |
| Inner corners: | Rounded for easy cleaning and ensuring maximum hygiene |
| Handle: | In AISI 304 stainless steel |
| Racks and slides: | Stainless steel AISI 304 |
| Feets: | Stainless steel AISI 304, adjustable h 100-150 mm |
| Cosmo: | Wi-Fi remote control system |

Accessories and variants

- RAL customisable colouring
- Plug-in water unit
- Power supply frequency 60Hz
- Other special voltage
- Purity C Quell ST 50 filter cartridge
- 4 Swivel and brake castors h 128 mm
- Aluminium coated backing-pan EN60x40 h 20 mm
- Stainless steel shelf EN60x40
- Plastic coated shelf EN60x40
- Pair of type L slides 398 mm EN
- Serial interface, RS485 cable

COSMO - wi-fi control

Cosmo is the wi-fi technology that allow to connect, update and monitor with a smartphone the VISION retarder prover devices. VISION is also a Cosmo hub and allow remote supervision of the Coldline devices connected to it. From the app you can check the operating conditions of each machine and receive alerts in the event of abnormal operation.

*The installation requires a kit for the replacement of the racks

Technical draw

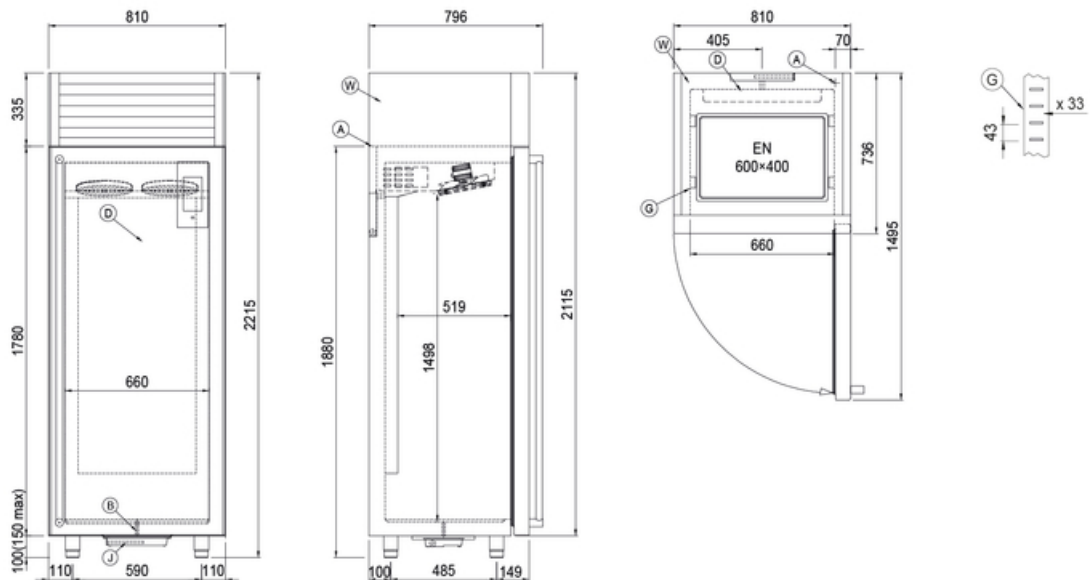

- | | | |
|-------------------------------------|---|---|
| A: Power supply cable outlet | B: Condensation water drain | D: Airflow conveyor |
| G: Racks pitch | J: Automatic evaporation of condensing water | W: Water mains connection for humidifier - 3/4" female. Unloading not required |

In order to constantly offer the best possible products we reserve the right to make changes on technical specifications without incurring any obligation for equipment previously or subsequently sold.